



AVID Vehicles Ltd

Sustainable Vehicle Technology



# express group

Major Investments  
(Collective Turnover Circa £40 million)



United Kingdom

Brazil

**Responsive Engineering**

**Weldex**  
Specialist welding & fabrication

**Pressex**  
Pressing & Mechanical assembly

**Streamline**  
Laser & Waterjet cutting specialists

**Exact Engineering**  
Toolmakers & Precision Engineers

MSI Holdings



Rapid Mouldmakers & Injection Moulding

express holdings

Regeneration NE

Holborn

Northern Property Partnerships



TTA

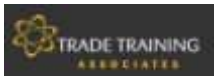

Transform Training

Contract Manufacture

Employees 125

Subcontract Engineering

Employees 110

Automotive Electronics

Employees 25

Product Development

Employees 20

Property

Employees 10

Online Services

Employees 20

Training Services

Employees 30



# Group Structure

## MSI Holdings Limited

### ComeSys Europe Ltd

[www.comesyseurope.com](http://www.comesyseurope.com)

Established November 2003

3 key business areas supplying essential technology for low carbon vehicles:

- . Design & manufacture Drive by Wire control systems for low emission specialist vehicles
- . Design and manufacture of advanced thermal management systems to reduce fuel consumption & emissions.
- . Design and manufacture of mobile electronics, instrumentation systems and remote vehicle data logging solutions

Established global customer base and sales channels. High future growth potential & established key supplier to leading commercial, industrial, agricultural, construction and electric vehicle manufacturers. Growth market due to increasing emission standards for vehicles resulting in wider adoption of electronic engine controls and successful launch of hybrid thermal systems.

### AVID Vehicles Ltd

[www.avidvehicles.com](http://www.avidvehicles.com)

Established August 2008

2 key business areas:

- . Design, Develop & Manufacture a unique range of zero emission vehicles using AVID M<sup>3</sup> powertrain technology.
- . Design, develop & test vehicles for OEM clients featuring AVID M<sup>3</sup> technology. Manufacture prototypes and technology demonstrators. Then aid OEM's to set up manufacturing using AVID systems and technology.

Established customer base with orders of £9M+ in place. High future growth potential due to market demand for zero emission vehicles, high profile customer base and involvement in North East England regional development agency key strategic projects. 10,000ft<sup>2</sup> production facility in Cramlington, Northumberland.

# ComeSys Europe Ltd facilities

- Ⓢ 5000 sqft production facility in North East England
- Ⓢ Strong R&D Team with 7 Professional Engineers
- Ⓢ Core areas of expertise:
  - Mechatronic design
  - Non Contact Sensor Design
  - Electronic component design
  - Systems Integration
  - Production test equipment and software
- Ⓢ Test Laboratory
  - Endurance test rig
  - Electronics test bench
- Ⓢ Lean Assembly Cells
- Ⓢ Warehousing and Logistics
- Ⓢ Training Room
- Ⓢ ISO 9001:2000 Certified ISO TS 16949 2007



# ComeSys Drive by Wire Controls

ComeSys accelerator pedals and position sensors are used by specialist vehicle manufacturers throughout the world.

ComeSys supplies standard products from its own range and also develops customised solutions for customers.

Patented Non-Contact position sensor technology and robust mechanical designs give higher performance than competitors products.

Lean manufacturing methods ensures outstanding value for money.



# ComeSys Advanced Thermal Management Solutions

ComeSys Advanced Thermal Management solutions lead the market for high performance vehicle cooling systems, electric and hybrid vehicles and parasitic loss reduction in large engines.

High performance CAN enabled brushless electric water pump WP29.

High performance CAN enabled brushless electric cooling fan F11.

Mini Hybrid fan systems for city buses delivering up to 15% improvement in fuel consumption.



# ComeSys Mobile Electronics

ComeSys mobile electronics platforms provide cost effective solutions for a wide variety of control, instrumentation and data logging applications.

Programmable multi function CAN enabled electronic controller CANecu.

Programmable CAN enabled display system CANDis.

CAN enabled remote vehicle data monitoring with GPS tracking and data collection via GPRS, VRDM.

Customised solutions for vehicle power management and speed control.



# ComeSys Customers



# AVID Vehicles introduction

- Ⓞ AVID stands for:
  - **A**dvanced **V**ehicle **I**nnovation and **D**evelopment
- Ⓞ The business was spun out of ComeSys Europe Ltd in 2008 to build upon activity in the Electric and Hybrid sector and provide a better service to existing customers
- Ⓞ The founding Directors of the business have over 75 years combined industry experience in electric / hybrid systems and vehicle design, manufacture and testing from board level at global OEM's and component manufacturers
- Ⓞ AVID has developed a novel approach to electric vehicle powertrain Multiple Motor Management "M<sup>3</sup>" Technology. M<sup>3</sup> technology allows AVID to deliver powertrain solutions which are highly competitive in terms of their performance and cost. Facilitating wider adoption of electric vehicles.
- Ⓞ 2 Core activities
  - Providing engineering development of zero emission powertrain and prototyping for global OEM's
  - Developing niche vehicles for sale under AVID brand

# Management Team

- Ⓢ **Ryan Maughan** BEng, MSC, CMgr, MIMechE
- Ⓢ Managing Director
- Ⓢ Previous Experience:
  - Operations Director, ComeSys Europe Ltd – specialising in drive by wire and electronic vehicle control system development
  - Senior Race Engineer, Cirtek Ltd – responsible for a number of race car development and competitive programmes with Porsche, Lister Cars, Marcos Cars, Rover Cars, Volkswagen and others. Including successful wins at Le Mans, Daytona, British GT Championship, FIA GT Championship, and others
- Ⓢ Ryan is an expert in vehicle control system design and vehicle electrical system integration

- Ⓢ **Ron Scott** BSc, CEng, MIMMM
- Ⓢ Research Director
- Ⓢ Previous experience
  - Director ComeSys Europe Ltd – successfully established ComeSys as a specialist in drive by wire vehicle controls
  - Founder Metaltech Ltd – established in 1980 a specialist heat treatment and metallurgical consultancy business. Has carried out many development projects for major global OEM's in fields such as chassis durability, drive train analysis and data logging and failure investigations
  - Metallurgist British Steel Corporation
- Ⓢ Ron is an expert in vehicle testing and durability prediction and measurement
- Ⓢ Ron also drive's the company's research strategy

- Ⓢ **Chris Baylis** HNC, OND, MIOD
- Ⓢ Engineering Director
- Ⓢ Previous experience:
  - Engineering Director, Antonov Transmissions PLC
  - Engineering Director, Delphi Automotive Systems
  - Engineering Director, Federal Mogul Braking Systems
  - Chief Design and Development Engineer, Nissan Technology Centre Europe
  - Chief Engineer Vehicle Safety / Chassis Design, Jaguar Cars PLC
- Ⓢ Chris is a specialist in vehicle and chassis design and development having a proven track record at major global OEM's

# Business focus

- ④ **Modelling and analysis** of vehicle energy requirements using advanced computer simulation techniques developed over 10 years of research.
- ④ **Design** of electric, hybrid or hydrogen fuel cell vehicle drivetrain systems based on simulation results
- ④ **Manufacture** of low to medium volume vehicles, prototypes and technology demonstrators for using our powertrain systems
- ④ **Test and validation** of systems using expertise of powertrain technology and state of the art methodology

# Modelling and analysis

- 🕒 Vehicle energy flow modelling
- 🕒 Vehicle design modelling
- 🕒 Energy analysis
- 🕒 System feasibility
- 🕒 Develop requirements for system design

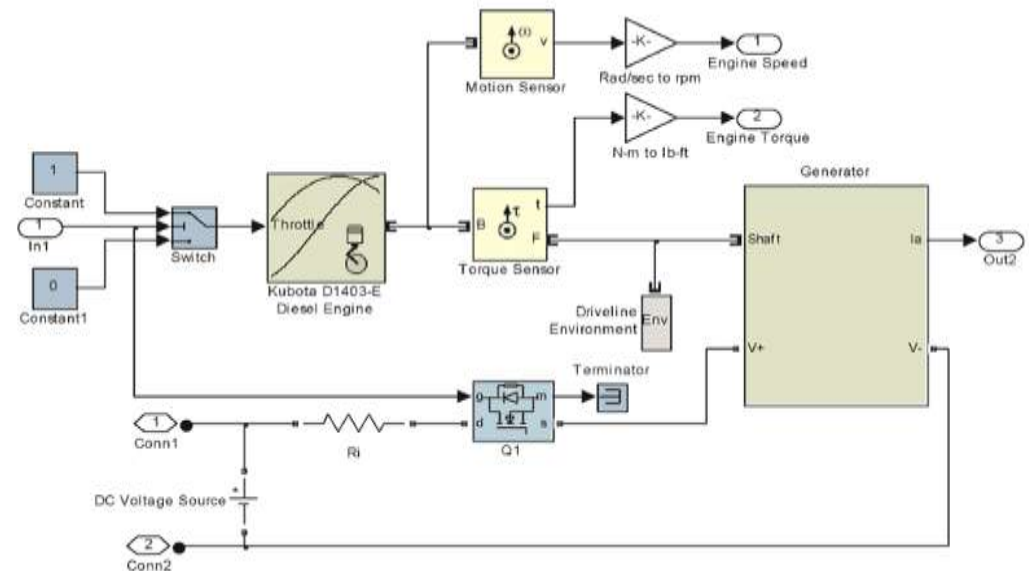

# Design

- Ⓢ Full specialist vehicles design capability 3D and 2D modelling and FEA
- Ⓢ Powertrain design and integration capability
- Ⓢ Fuel cell system design
- Ⓢ Design validation
- Ⓢ Powertrain installations
- Ⓢ Electronic control systems

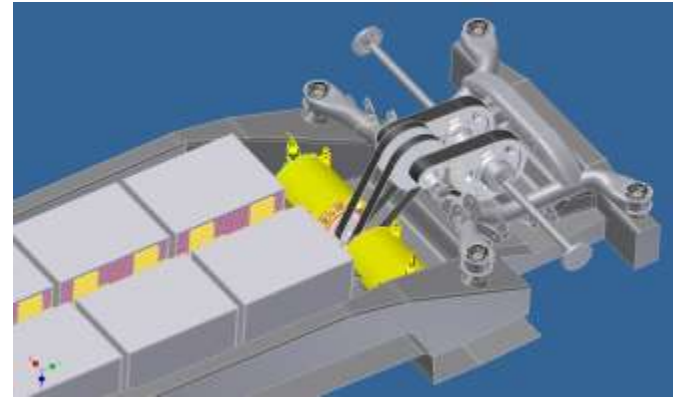

# Manufacture

- Ⓢ 10'000 sqft secure facility using cellular production system
- Ⓢ Construction of prototype vehicles
- Ⓢ Conversion to electric, hybrid and fuel cell drivetrain
- Ⓢ Conversion of old vehicles to new powertrain
- Ⓢ Mini-Hybrid system installations on bus and trucks
- Ⓢ Projects range from 1 off to small production runs of up to 500 vehicles
- Ⓢ Maximum privacy guaranteed



# Test and validation

- Ⓢ Expertise in powertrain testing and reliability
- Ⓢ Whole vehicle reliability testing
- Ⓢ Individual component test and validation
- Ⓢ EU market type approval assistance
- Ⓢ Whole vehicle or component certification expertise



# AVID programme management

## Vehicle Level Project

- ⌚ Agree the scope of vehicle project with client e.g:
  - 1 off prototype to be engineered for specific purpose for client.
  - Low volume 2 to 100 off engineered for a specific purpose.
  - Low volume vehicle engineered for sale on to an end customer.

## Sub system Level projects

- ⌚ Establish system design specification with customer.
- ⌚ Agree spec tender package with customer for AVID.

## Component Level projects

- ⌚ Agree spec tender package with customer for AVID.

## Project management

- ⌚ All projects will have a Critical Path Plan
  - A clear project plan agreed between AVID and customer / client.
  - Status gateways will be agreed and monitored at review meetings.
  - Gateways can be used as payment stages, to be agreed with client.
  - Unforeseen problem recovery actions taken as required / agreed between AVID & the client at any stage in the project.

# AVID programme management

## Vehicle Test & Sign Off

- Ⓢ AVID testing will be carried out as agreed with the client.
- Ⓢ AVID has access to many test facilities for this work.
- Ⓢ Some client specific testing will require access to their facilities.

## Sub system Test & Sign Off

- Ⓢ Testing will be carried out to meet AVID and client specification.
- Ⓢ Testing will require the close cooperation of the client for surrounding architecture.

## Component Level Testing & Sign Off

- Ⓢ Agree test requirement in spec tender package with customer.
- Ⓢ Testing will normally be an AVID bench test.

## Project management

- Ⓢ Reports written and problem resolutions recorded.
- Ⓢ Performance problem resolution will follow 6, 8 or 9 D process.
- Ⓢ Fit problems will be a recorded drawing revision.

# AVID system architecture

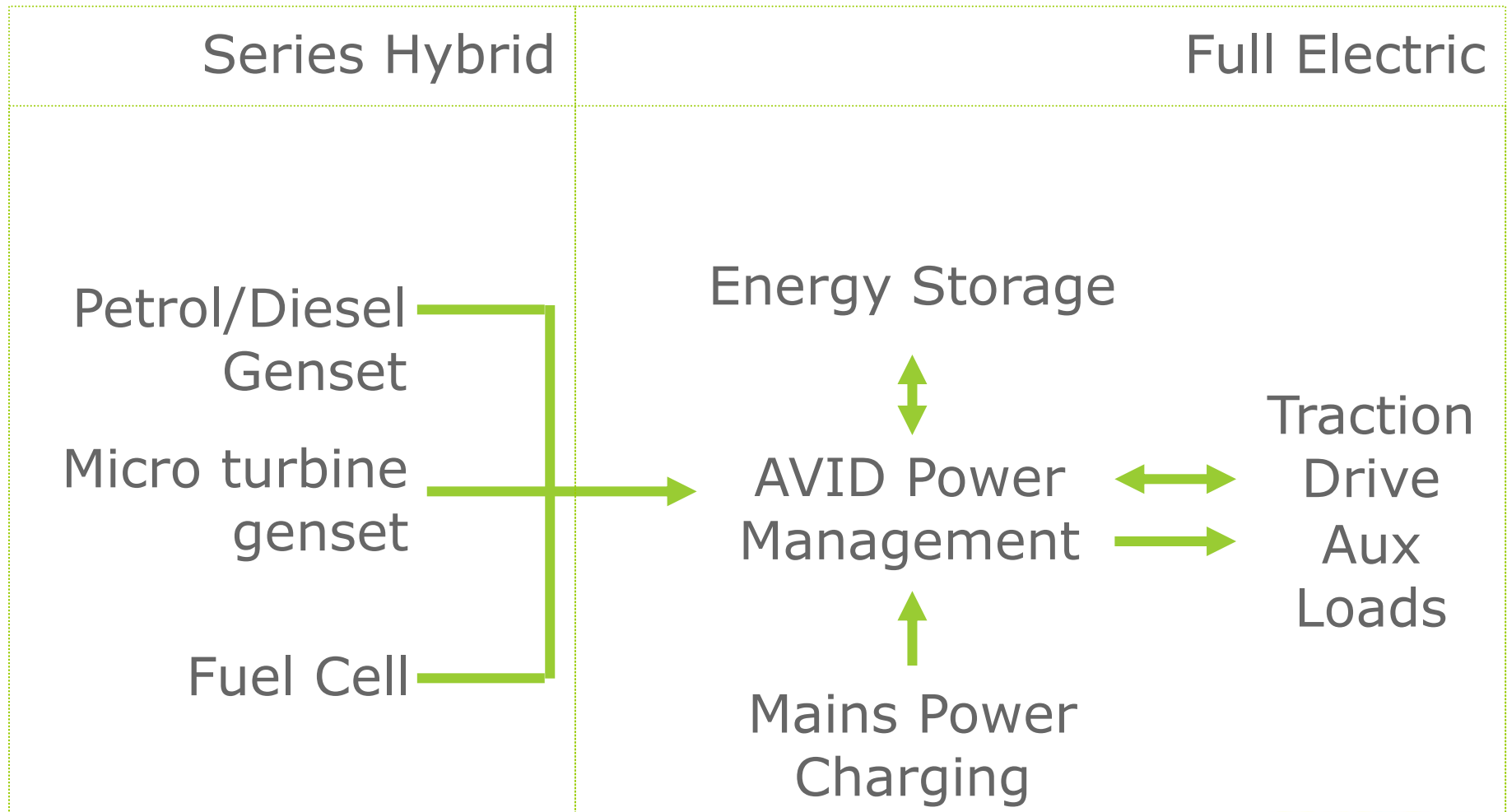

# AVID M<sup>3</sup> system

- Ⓢ Unique AVID IP relating to system control and topology
- Ⓢ Distribute traction power by using multiple motor system
- Ⓢ Eliminate differentials and mechanical transfer cases
- Ⓢ Control motors independently to distribute torque efficiently
- Ⓢ Reduce motor and controller power factors
- Ⓢ Reduce system losses

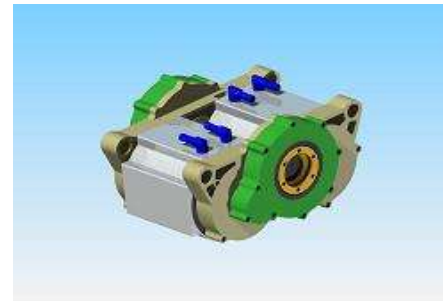
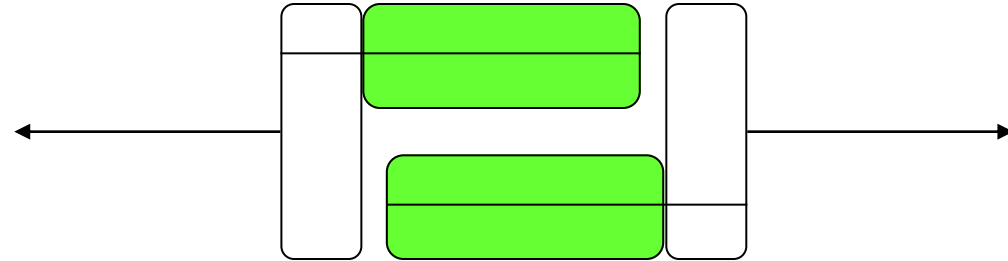

# AVID Niche Vehicles – E-Warrior

## All Electric 4 Wheel Drive Utility Vehicle

- Fully electric drive
- Zero Emission operation
- Low noise
- Low running costs
- High power twin motor
- AVID M<sup>3</sup> Motor System
- Fully road legal
- Proudly built in the U.K.



## Specifications

L x W x H:	2.9m x 1.4m x 1.8m
Wheelbase:	1910mm
Ground Clearance:	300mm
Transmission:	4 Wheel Drive Twin Motor
Braking System:	Disc brakes all round
Unladen Weight:	600kg
Load Bed Capacity:	250kg
Towing Capacity:	550kg
Battery Voltage:	48V
Motor Power:	43kW (Max)
Charging System:	240V / 13Amp
Range:	Up to 50 Miles

# AVID Niche Vehicles – E-Warrior

## Outline Vehicle Specification:

### 🔌 **E-Warrior**

- 🔌 600kg kerb weight.
- 🔌 50 miles or 1 day typical agricultural work range.
- 🔌 Top speed limited to 50kph.
- 🔌 2x 48v Permanent Magnet AC Motor (15kW Nominal Each)
- 🔌 48v (Nom) Battery pack Lead Acid as standard. Li-Ion available as optional extra.
- 🔌 Fully EU road legal
- 🔌 Regenerative braking to put energy back into batteries.
- 🔌 Optional extras:
  - Front mounted winch
  - Towing kit
  - Weather kit
  - Half doors

# Electric UTV layout

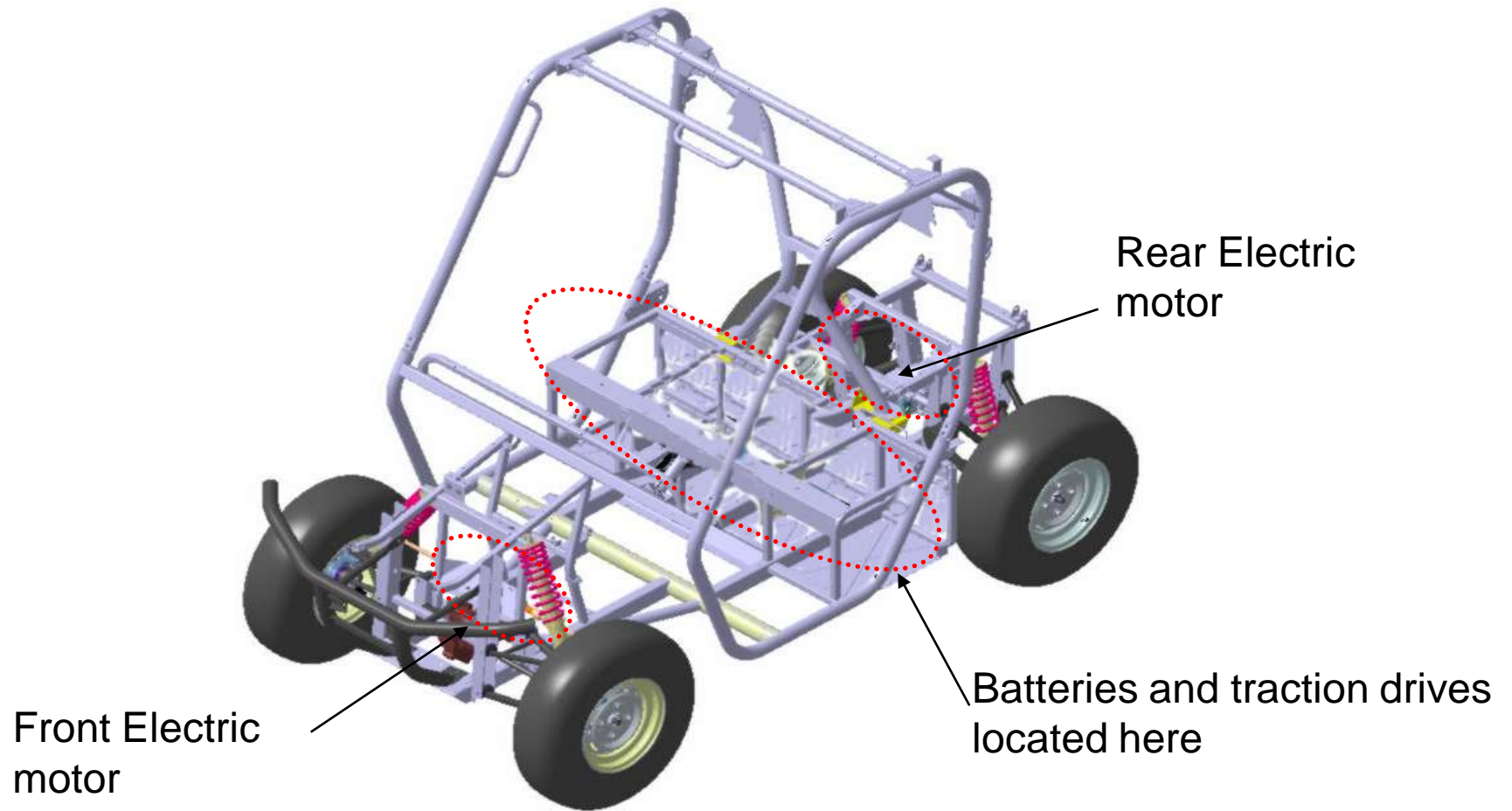



# AVID vehicles – CUE-V

## Compact Urban Electric Vehicle

- Fully electric drive
- Zero Emission operation
- Low noise
- Low running costs
- High power twin motor
- AVID M<sup>3</sup> Motor System
- Fully road legal
- Proudly built in the U.K.



## Specifications

L x W x H (m):	3.75 x 1.665 x 1.555
Interior (m):	1.835 x 1.4 x 1.27
Wheelbase:	2440 mm
Ground Clearance:	160 mm
Min turning radius:	4.7 m
Unladen Weight:	1050kg
Seating capacity :	5
Motor Power:	30kW
Charging System:	240V / 13Amp

# AVID vehicles – CUE-V

## The Proposed Vehicle Specification:

- Ⓢ Vehicle – AVID Vehicles Ltd - AVID CUE-V.
- Ⓢ 1,050kg kerb weight.
- Ⓢ 100 miles + safe range (50 miles in & out of a city) plug in energy supply.
- Ⓢ 0 to 60 mph in 9 seconds.
- Ⓢ 80 mph + Cruising on Motorway / Autobahn.
- Ⓢ Max speed 90 mph.
- Ⓢ 2x 100v AC Motor 15kW (Siemens or another high volume motor).
- Ⓢ 100v Battery pack LiFePO4 250 Amp peak 120 Amp continuous (260kg / 183 litres).
- Ⓢ Regenerative braking to put energy into batteries and super capacitors.
- Ⓢ Super capacitor system to further reduce battery size.

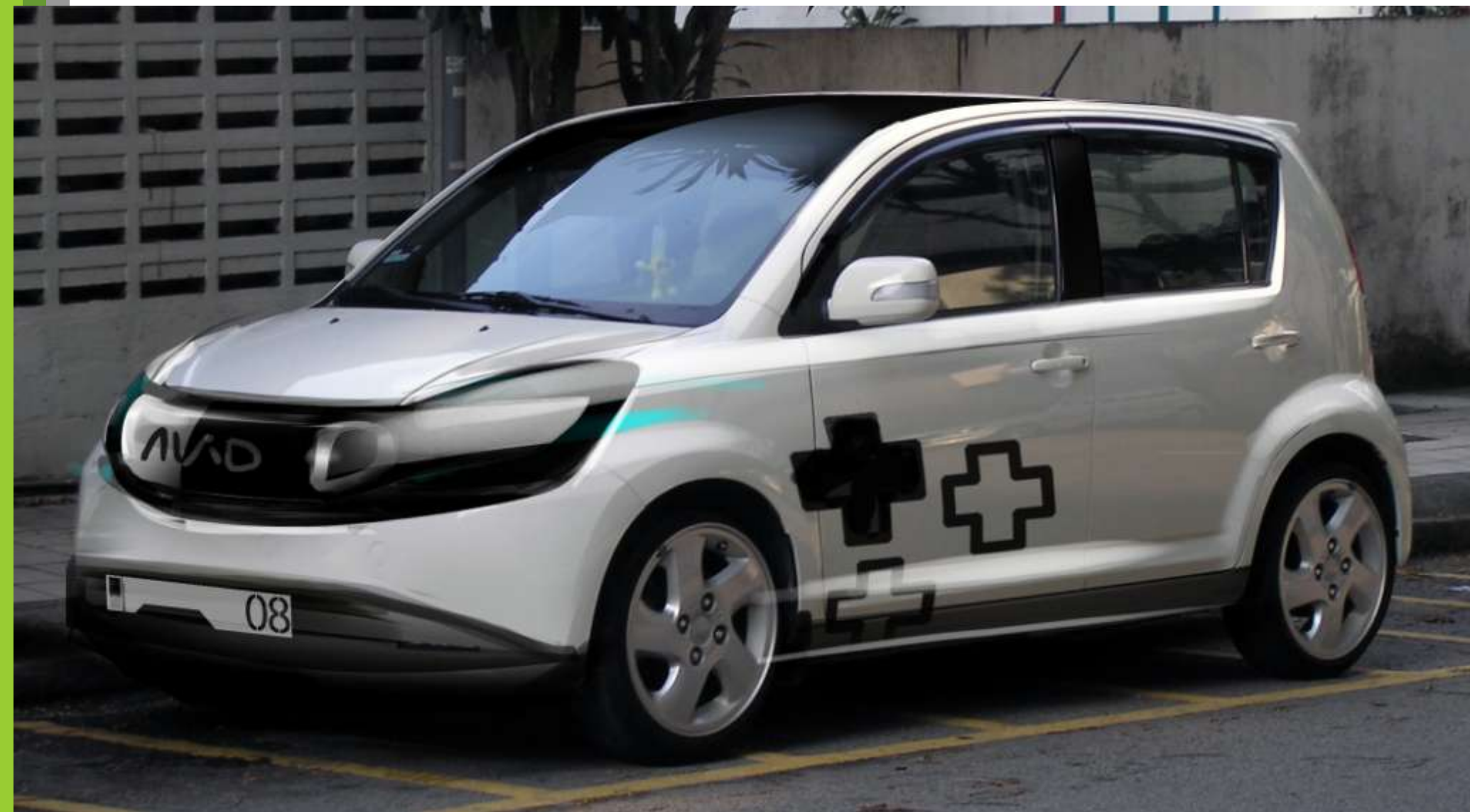

Confidential AVID Vehicles Ltd 2009



# Technical Partners



# Academic links



AVID works closely with the renowned Power Electrical Drives and Machines research group at Newcastle University



AVID works closely with the AMAP research group at Sunderland University