

Development Control Process

Key:-

- MAC / MA 'As of Right' Work
- MAC / MA Work at Highways Agency's Discretion
- Development Control / Planning Consultants Work at Highways Agency's Discretion

DCM = Development Control Manager (Normally PB6)
ADCM = Assistant Development Control Manager (Normally PB5/PB4) (See Note 2)
MAC/MA = Managing Agent Contractor/Managing Agent
LPA = Local Planning Authority
TO = Traffic Operations
NS = Network strategy
ITB = Influencing Travel Behaviour
TPI = Targeted Programme of Improvements
RMS/LUDCS = Route Management Strategy/Land Use Development Control Statement

Note: The DCM & ADCM are functional titles indicative of the roles undertaken rather than descriptive of the specific posts occupied.
 Publications Group B040096.ai

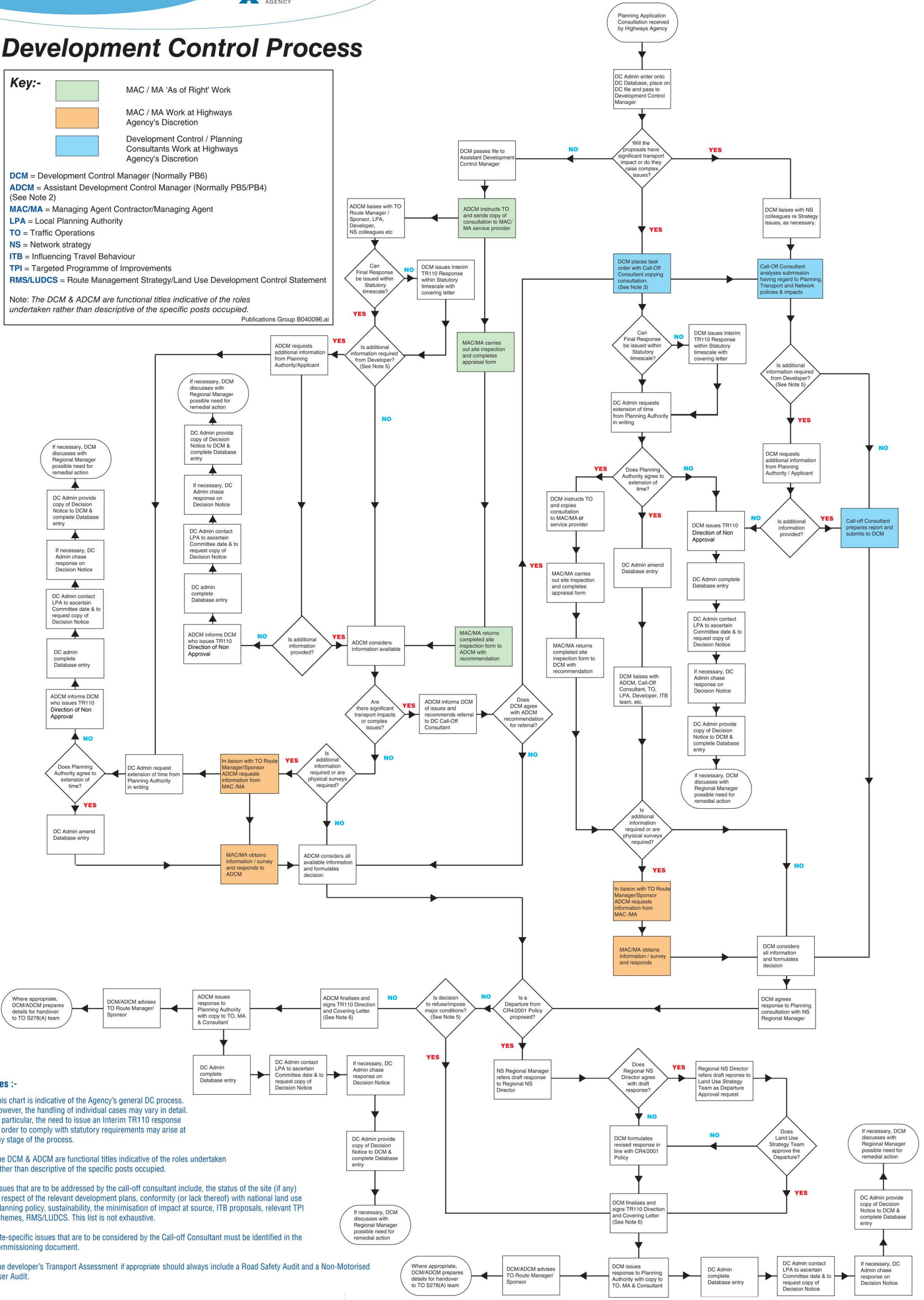

Notes :-

1. This chart is indicative of the Agency's general DC process. However, the handling of individual cases may vary in detail. In particular, the need to issue an Interim TR110 response in order to comply with statutory requirements may arise at any stage of the process.
2. The DCM & ADCM are functional titles indicative of the roles undertaken rather than descriptive of the specific posts occupied.
3. Issues that are to be addressed by the call-off consultant include, the status of the site (if any) in respect of the relevant development plans, conformity (or lack thereof) with national land use planning policy, sustainability, the minimisation of impact at source, ITB proposals, relevant TPI schemes, RMS/LUDCS. This list is not exhaustive.
4. Site-specific issues that are to be considered by the Call-off Consultant must be identified in the commissioning document.
5. The developer's Transport Assessment if appropriate should always include a Road Safety Audit and a Non-Motorised User Audit.